

Lago Basic 0101/1001

Boiler module/Mixer
controller

Operating and
Installation Instructions



Please observe the safety instructions and read through this manual carefully before commissioning the equipment.

Safety information

Power connection regulations

Please note the connection conditions specified by your local electrical power supply utility and the VDE regulations. Your heating control system may be installed and serviced only by appropriately authorised specialists.

- ⚠ For fixed devices, a facility for mains disconnection in accordance with EN 60335 must be installed in compliance with the installation specifications (e.g. switch).
- ⚠ The mains lines insulation must be protected against damage caused by overheating (e.g. insulation hose).
- ⚠ The minimum distance to installation objects in the vicinity must be chosen so that the permitted ambient temperature is not exceeded during operation (see table - Technical data).
- ⚠ If the system is not installed properly, persons using it are at put at risk of fatal or serious injury (electric shock). Ensure the controller is de-energized prior to performing any work on the controller!

Safety

Please read and keep in a safe place



Please read through these instructions carefully before installing or operating. Following the installation, pass the instructions on to the operator.

Warranty conditions

If the system is not installed, commissioned, serviced and repaired professionally, this will render the manufacturer's warranty null and void.

Conversion

All technical changes are prohibited.

Transport

On receipt of the product, check that the delivery is complete. Report any transport damage immediately.

Storage

Store the product in a dry place. Ambient temperature: see Technical data.

Important text passages

- ! Important information is highlighted with an exclamation mark.
- ⚠ This attention symbol is used to point out dangers in this manual.

General Notes

- ! With regard to installation, operation, and maintenance, the following instructions must be observed. This device must only be installed by a specialist technician. Improperly performed repairs can subject users to considerable risks.

! To comply with applicable regulations, the instructions for assembly and operation must be readily available at all times and must be handed over to the responsible engineer when working on the device for his attention.

Installation

Information on installation of the system is provided in Part 2 of this manual together with a connection diagram.

Description

Declaration of conformity



We the manufacturer declare the product Lago Basic 0101/1001 is in conformity with the fundamental requirements of the following directives and standards.

Directives:

– 2004/108/EC, 2006/95/EC

Standards:

– EN 60730-1, EN 60730-2-9

The manufacture is subject to the quality management system in accordance with DIN EN ISO 9001.

General Function

- Control of a fixed flow temperature or a fixed return flow temperature via control of a heat generator or a mixer.
- It is possible to connect a room thermostat or a timer switch (24 V).
- Hot water function via sensor or thermostat.
- Weather-dependent and room temperature dependent control of a flow temperature via control of a heat generator or a mixer (time guidance only with additional module).
- Heating module in a cascade

General information	2	Functions	12
Safety information	2	Operation without operating module	12
Power connection regulations	2	Control of the flow temperature	12
Safety	2	Mode of operation cooling	
Warranty conditions	2	(only as 1001 mixer operation)	13
Important text passages	2	Operation using operating module	13
General Notes	2	Zone control	13
Installation	3	Warm-up temperature (HS min. – 5 K)	13
Description	3	Frost protection function	13
Declaration of conformity	3	DHW Relief	14
General Function	3	Circulation pump control	
Operation	6	(not in the case of a fixed value)	14
Explanation of the operating elements	6	Special functions	14
Rotating switch	6	EEPROM check	14
Incremental encoder / Shaft encoder	6	Pump blocking protection	14
Key STL-test / Enter / Reset	6	Mixer motor blocking protection	14
Settings via DIP switch (rear side)	6	Delayed pump switch-off	14
Display (normal mode "Run")	7		
Symbols below the display	7		
Starting up	8		
Modifying set values	8		
List of the User Set Values	8		
Explanatory information	9		
Set values	9		
Settings via DIP switch (rear side)	11		

Installation	15	Remote controls	23
Assembly / Dismantling	15	The operating module Merlin BM, BM 8, Lago FB	23
Dimensions	15	Remote control FBR2	23
Electrical connection Controller	16	Sensor resistances FBR	24
Electrical connection, base	17	PC	24
Options	18	Maximum delimiter	24
System diagrams	19	Telephone switch	24
Boiler controller with direct heating circuit and Hot water	19	Sensors	25
Boiler controller with Header pump / mixer motor expansion	20	Outside sensor AF (AFS) \triangle -	25
Boiler controller in cascade operation	22	Immersion sensor KF (KFS) \Rightarrow / SPF (SPFS) \curvearrowright	25
		Strap-on sensor VF (VFAS) \boxtimes	25
		Sensor values / characteristic curve	26
		Errors	26
		Technical data	27
		Glossary	27

Explanation of the operating elements

Rotating switch

RUN Automatic mode

To the left:

 Standby (frost protection only) KMBurner OFF, heating circuit pump OFF, hot water function OFF

MM: Mixer CLOSED, heating circuit pump OFF

 Manual operation (emergency mode/service)

KM: Burner ON, heating circuit pump ON, hot water charging pump ON

MM: Heating circuit pump ON

in the case of Prog. key => Relay test with incremental encoder

BUS ID (boiler or heating circuit number)

To the right:

 with room / outside sensor: Room set temperature

 in the case of fixed value: Flow / Return flow set temperature in the case of control mode: Maximum flow temperature

 with room sensor: Room sensor influence

 with outside sensor: Heat slope

 /  KM: Hot water set temperature
MM: Mixer dynamics

Incremental encoder / Shaft encoder

- Adjusting a set value

Key STL-test / Enter / Reset

STL-test (RT without effect) => By pressing > 1 sec => Burner on, for as long as key is pressed, display: HS-Temp flashes (no function as mixer)

Enter (modify set values) => Selection of parameter for adjustment (flashing); Save by pressing again => for temperature readouts: Display set value (for 2 seconds)

RESET: In order to reset the controller to the default setting, keep the key pressed while defining the operating voltage (display "EE") All user values will be lost during this procedure! For this reason, please take a note of your own parameters in this manual.

Settings via DIP switch (rear side)

! Settings 1 - 5 only take effect if used as control for a heat generator (HS) when no corresponding operating module is connected.

- 1 + 2: OFF,OFF => No HS minimum delimiter
OFF,ON => Minimum delimiter when burner ON
ON,OFF => Minimum delimiter when heating requirement
ON,ON => Minimum delimiter 24 h
- 3: Selection HS minimum delimiter HS minimum temperature (40 °C <-> 60 °C)
- 4: Parallel operation OFF/ON
- 5: Antibacteria function OFF/ON
- 6: Sensor selection: 5 k NTC <-> 1 k PTC

Factory setting DIP switch 1 - 6 OFF

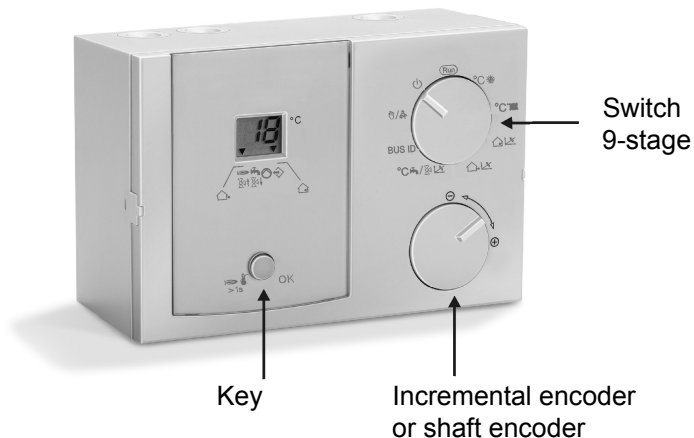

Display (normal mode "Run")

The display shows the flow temperature of the heat generator or the heating circuit. When the incremental encoder is rotated, the following temperatures are displayed: 1. Outside temperature (⏏, arrow 1), 2. Hot water temperature (⚙, arrow 2) => key: Set value 3. Room temperature (⏏, arrow 4) => key: Set value

Display „- - „ => No measured value available.

Symbols below the display

KM:

- ⏏ // ⚙↑ = Burner ON
- ⚙ // ⚙↓ = Charging pump ON
- ⊙ = HS pump ON // HC pump ON
- ⚡ = Communication OK!

MM:

- ⏏ // ⚙↑ = Mixer opens OPEN (arrow points upward)
- ⚙ // ⚙↓ = Mixer closes CLOSE (arrow points downward)
- ⊙ = HC pump ON
- ⚡ = Communication OK!

If an arrow points towards one of the printed symbols, the corresponding function is active.

Starting up

After the device has been properly installed (please observe the switch position on the rear side of your device), switch on the power supply.

The software number for your device and then the index of your software briefly appears in the display.

Then the readout appears in accordance with the position of the rotating switch.

The controller is now operational => "Run"

Modifying set values

Rotate the selection switch to the corresponding set value

The display shows the currently set value.













Press the OK key.

The value starts to flash and can now be changed using the rotary knob.

By pressing the button key OK once more, the value is stored in the device.

Rotate the rotating switch to RUN Automatic mode => the mode is activated after 2 seconds.

List of the User Set Values

Designation	Area	Factory	Values
Run => Normal mode Display level with shaft encoder	--		
°C  = Room set temperature*)	5 – 40 °C	20 °C	
°C  = (MAX T-HS = 95 °C) = in the case of fixed value => Flow / Return flow set temperature*) in the case of control mode => Max. flow temperature*)	20 – 110 °C	40 °C 80 °C	
  = Room sensor influence*)	00 – 20	10	
  = Heat slope*)	0.0 – 3.0	1.2	
°C  = only HS controller Hot water set temperature*)	10 – 70 °C	60 °C	
  = only mixer controller Mixer dynamic	05 – 25	12	
BUS ID => KM: HS number MM: Heating circuit number	--,00-08,11-88 01 – 15	-- 01	
  Manual operation (emergency mode/service) Prog key = Relay test	00 – 03	00	
 Standby (OFF or only frost protection)	--		

*) ! These values are set on the matching operating module (KM: address 00/01; MM: address of mixer) if such a module is connected.

Set values

Room set temperature

Only effective if an outside sensor or a room sensor (without operating module) is connected.

=> Setting the desired room temperature

Flow set temperature (fixed value)

Only takes effect if no outdoor sensor, room sensor, or operating module is connected.

=> Input of the desired flow / return flow temperature.

Maximum flow temperature

If an outdoor sensor or a room sensor is connected

The measured temperature setting for the heating circuit flow is limited to the maximum flow temperature setting (overheating protection).

△ The heating circuit pump of the direct heating circuit is switched off if the temperature of the heat generator exceeds the maximum flow temperature by 8 K. The heating circuit pump is switched on again when the temperature of the heat generator drops below the temperature [maximum flow temperature + 5 K].

Room sensor

Only active if a room sensor or the FBR analogue room device (room sensor + selection of operating mode) is connected..

The flow set temperature is increased by the set value when the temperature drops below the required room temperature by 1 K.

=> High values lead to fast control and large heat generator temperature fluctuations.

- - - - => pure weather-dependent control

0 => pure weather-dependent control *)

20 => pure room temperature control

*) Special function with ROOMS-INFL = 0

For one-off heating requirements during the night reduction the heating pump continues to run until the next heating period is reached (see chapter entitled "Circulation pump control").

Heat-Slope

Only active if an outside sensor (without operating module) is connected.. The gradient of the heat slope indicates by how many degrees the flow temperature changes if the outside temperature rises or drops by 1 °C.

Setting tip:

At cold outside temperatures, room temperature too low => Increase heat slope (and vice-versa)

At high outside temperature (e.g. 16 °C) room temperature too low => correction via set room temperature

Flow temperature [°C]

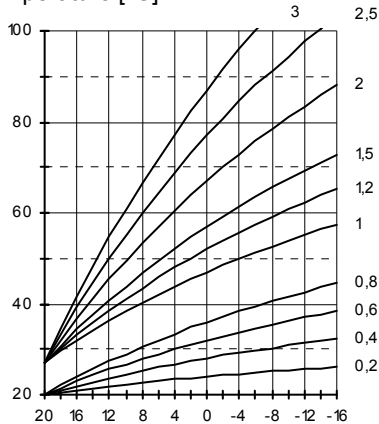

Heat slope diagram (setting aid)

Setting 0 => Room control only

! The heat slope can best be set at outside temperatures below 5 °C. The change in heat slope setting must be made in small steps and at long intervals (min. 5 to 6 hours) because the system must first adjust to the new values each time the heat slope is changed.

Guideline values

- Underfloor heating S = 0.4 to 0.6
- Radiator heating S = 1.0 to 1.5

Hot water set temp. (only in the case of boiler module)

Setting the desired hot water temperature. This temperature is stabilised in the storage tank for 24 h

HW thermostat instead of HW sensor: Hot water preparation in the event of short circuit on the sensor input.

If a corresponding operating device is connected the hot water function is only activated during hot water enable times.

Mixer dynamic (only in the case of mixer module)

Speed setting at which the mixer motor adjusts when a control difference occurs. The control difference at which the mixer motor opens/closes without interruption is entered in Kelvin.

! Small values cause the mixer motor to adjust quickly and can lead to oscillation.

BUS-ID (heating circuit number)

KM: [- -] HS with direct heating circuit and Hot water
 [00] HS with header pump and Hot water
 [01 - 08] [11-88] HS in a cascade with HS-Pump
 => Enter number of the heat generator. Setting > 08 can be supported only during cascading by cascades with appropriate cascade managers.

MM: The heating circuits are sequentially numbered starting with "01". heating circuit numbers must not be assigned twice. For replacement controllers, please enter exactly the same heating circuit numbers as the replaced controller.

Settings via DIP switch (rear side)

Switch 1 - 5 only valid in the case of HS controller without operating module

HS minimum delimiter (switch 1 + 2)

Reduces condensation build-up in boiler when heating requirement is low. In all cases, the heat generator is never switched off before the minimum boiler temperature has been reached + 5 K.

OFF, OFF = No HS minimum delimiter

OFF, ON = Minimum delimiter on heat slope

HS switches on when the temperature drops below the temperature demanded by the consumers (flow set temperature).

ON, OFF = Minimum delimiter during heat requirement

During heating requirement (pump enabled), the boiler maintains at least the set minimum temperature (40 °C or 60 °C).

ON, ON = Permanent minimum delimiter (24) The HS maintains at least the set minimum temperature for 24 h.

Minimum HS temperature (40 °C <-> 60 °C)

Reduces condensation build-up in boiler when heating requirement is low. In all cases, the heat generator is never

switched off before the minimum boiler temperature has been reached + 5 K.

Parallel pump operation (Ⅲ + Ⅳ)

OFF => HW partial priority: The heating circuits are blocked during hot water preparation. The mixers close and the heating circuit pumps switch off. The mixer circuits are enabled again when the heat generator has reached the temperature of [hot water set temperature + heat generator superheating]. If the heat generator temperature drops below the enable temperature by the switching hysteresis, the mixer circuits are blocked again.

ON => Parallel pump operation: During hot water heating all heating circles are continued to heat. The hot water heating is extended by this function.

Antibacteria function (Ⅲ -> 65 °C)

Every 20th heat-up operation, or once per week, the storage tank is heated to 65 °C.

Without operating module: In the case of first charging after one week has elapsed (Time indefinitely)

With operating module: On Saturday at 01:00 hrs.

Sensor selection (5 k NTC <-> 1 k PTC)

Check the installed sensors (imprint, type plate, or measurement value - see table) and set the switch accordingly.

Functions

Operation without operating module

When the controller is operated without an operating module (correspondingly, in the event of the bus connection to the operating module failing).

0101 => Heat generator module (with boiler sensor KF):

BUS ID - -: The heating circuit pump is running and the temperature at the heat generator is adjusted to the set flow temperature (fixed value) if the operating mode is positioned at RUN and the thermostat input is switched/bridged or the telephone switch is switched/bridged (= heating operation).

BUS ID 00: The heating circuit is deactivated, the pump is running as collector pump during hot water preparation or when there is a heating requirement from an external heating circuit.

The hot water storage tank is regulated to the set temperature. During hot water operation, the HS is regulated to the temperature HS set temperature + 20 K.

RUN: Hot water preparation 24 h enabled

Telephone switch closed: Hot water preparation enabled

1001 => Mixer module (without boiler sensor KF):

The flow temperature of the associated heating circuit or the return flow temperature of the heat generator (sensor position) is regulated to the flow temperature set value (fixed value) set at the controller. Here the set mixer dynamics forms the basis.

If an outdoor sensor is connected, a weather-dependent calculation of the flow set value is performed.

If a room sensor is connected, a room temperature dependent regulation to the specified room set value is activated.

Control of the flow temperature

Weather-dependent control

The heat generator or flow temperature is determined via the set heat slope to suit the measured outside temperature in such a way that the set value for the room is approximately set if the heating system is configured correctly.

=> Exact setting of the heat slope is extremely important for weather-dependent control.

The circulation pump is controlled weather-dependently. The circulation pump is switched on if there is a heating demand and in Frost-protection mode.

Room sensor influence

The current room temperature can be included in computation of the required flow temperature via a present room temperature sensor.

The influence factor (parameter list) can be set between 0 (fully weather-dependent regulation) and 20 (room temperature regulation with minimal outdoor temperature influence). Position "----" deactivates room temperature control. Positions "----" and "0" indicate differences for demand-dependent circulation pump control.

Mode of operation cooling (only as 1001 mixer operation)

The air conditioning by the central automatic controller is supported. When activation over BUS: Mixer open and pump on and/or regulation on advance desired value by a BM.

Operation using operating module

0101 => Heat generation module: The operating module calculates the requirement for the heat generator. This temperature is provided by the controller. The pumps and the burner are controlled accordingly.

1001 => Mixer module: The mixer adjusts the temperature to the ideal flow temperature calculated by the operating module. The operating module functions are described in the corresponding operating module. For this purpose, the operating switch must be in the position Automatic (RUN).

Zone control

If separate outdoor sensors are connected to the different mixer modules, it is possible to implement a zone control. The outdoor sensor for the mixer circuits on the north side of a building can be installed on the north side; the outdoor sensor for the mixer circuits on the south side is installed on the south side of the building. This ensures that the relevant outside temperature is used for calculating the flow temperature.

Warm-up temperature (HS min. – 5 K)

Reduces operation in condensation zone. The circulation pumps are switched off and the mixers are shut until the boiler has reached the start-up temperature. The function is cancelled no later than 30 minutes after starting.

Frost protection function

The frost protection circuit prevents the heating system from freezing by automatically switching on the pump.

Flow sensor frost protection

The frost protection function is activated if the flow temperature drops below 7 °C.

The frost protection function is deactivated if the flow temperature rises above 9 °C.

Frost protection via room sensor

If the room temperature drops below 5 °C the frost protection function is activated.

The room temperature setting for the relevant heating circuit is set to 5 °C. The heating circuit is enabled:

- the pumps are switched on
- the heat request is sent to the heat generator

Outdoor sensor frost protection

The frost protection function is activated if the outside temperature drops below 0 °C. The heating circuit pumps are activated and the burner is enabled.

Should the outdoor sensor be defective, the frost protection temperature is included in the flow calculation.

DHW Relief

The charging pump is not switched until the boiler temperature exceeds the storage tank temperature by 5 K. It is switched off when the boiler temperature drops below the storage tank temperature. This prevents the storage tank from being cooled by the boiler when hot water preparation starts.

Circulation pump control (not in the case of a fixed value)

The circulation pumps are switched off if heating is not required. The mixers are closed at the same time (restart with 1 K hysteresis).

Heating time:

- Outside temperature > room set value + 1 K

Reduction period:

ROOMS-INFL = 0:

- The switch-off occurs during the transition to reduction operation.
- Restart: Room temperature < room set value The pump runs continuously after switching on.

ROOMS-INFL = "--,;:

- Flow temperature setting < 20 °C.

Special functions

EEPROM check

Every 10 minutes, a check is conducted automatically in order to establish whether the settings of the controller lie within the specified limits. If a value is found to be out-of-range, it is substituted by the related default value. The range transgression is indicated by the flashing error number 81.

In this case, the user should check the important settings of the controller. The error indication symbol goes out after the unit is restarted (RESET).

Pump blocking protection

The controller effectively prevents the pumps blocking following longer periods out of operation. The integrated protection function activates for 5 seconds all pumps that have not been in operation during the past 24 hours

Mixer motor blocking protection

If the mixer was not moved for 24 hours, it is fully opened once only. The heating circuit pump is switched off during this time. The maximum flow temperature is monitored. Cancelled at maximum flow temperature – 5 K.

Delayed pump switch-off

When a heat generator is shut off the assigned pump runs on for 5 minutes.

Assembly / Dismantling

Version 1 => Through the hole at the side

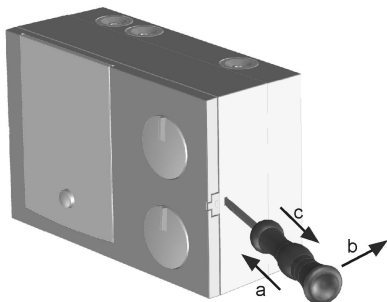

Version 2 => From the front

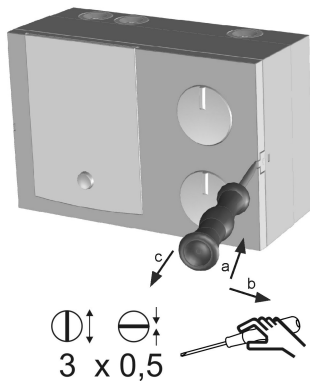

Mounting material, e.g.:

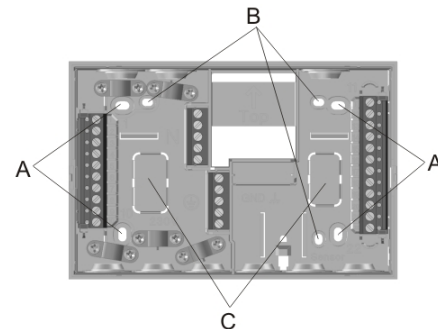
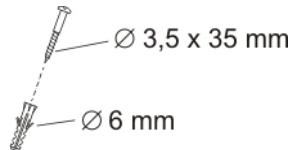

- A: Mounting holes
- B: Mounting holes, for assembly on switch box
- C: Breakthrough for leading cable through

Dimensions

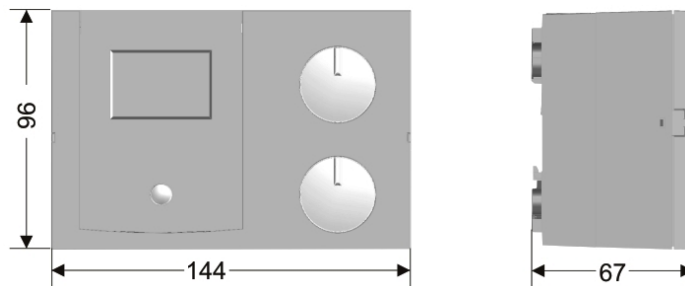

Electrical connection Controller

Safety extra-low voltage

~230 V; Relay switching capacity 2(2) A, ~250 V

11 - 14 CAN BUS

15 - 17 FBR2

alternatively:

15 + 16 Lago switch
or room thermostat

18 + 19 Storage tank

sensor

or HW thermostat
alternatively in the
case of mixer flow
sensor

19 + 20 Boiler sensor

21 + 22 Outdoor
sensor

in the case of mixer
for zone control

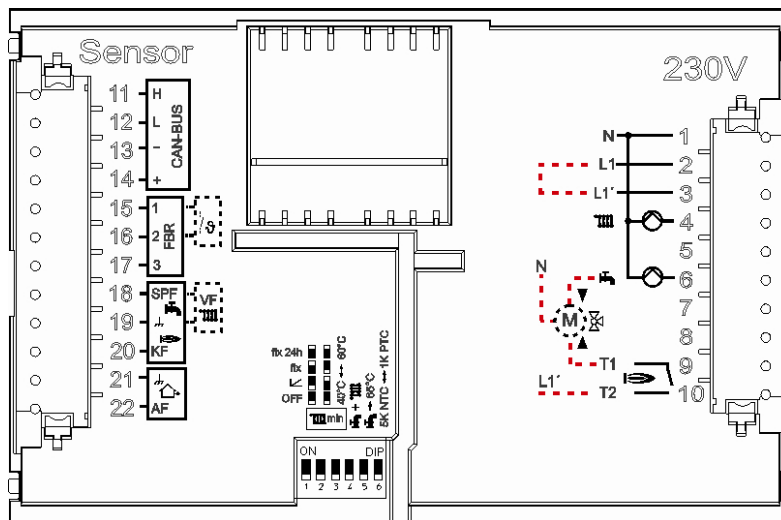

1 N-conductor, mains

2 Power supply, unit

3 Power supply, relay
(bridge 2 to 3)

4 Pump, heatcircuit / HW /
Header

6 Storage tank pump alter-
natively in the case of mixer
mixer CLOSED

9 + 10 Burner
Potential-free alternatively
in the case of mixer
mixer OPEN
(e.g. bridge 10 to 3)

⚠ **Attention:** For the connection (230 V) fixed or flexible lines with the factory-standard lead end sleeves are to be installed.

⚠ **Attention:** Bus lines and sensor lines are to be installed separately from supply lines!

! in the event of operation without room thermostat or with timer switch, short-circuit contacts 15 and 16 using a wire jumper.

Electrical connection, base

~230 V; Relay switching capacity 2(2) A, ~250 V

Safety extra-low voltage

- 1 N-conductor, mains
- 2 Power supply, unit
- 3 Power supply, relay (bridge 2 to 3)
- 4 Pump, heatcircuit / HW / Header
- 6 Storage tank pump alternatively in the case of mixer
- 9 + 10 Burner
Potential-free alternatively in the case of mixer
mixer OPEN
(e.g. bridge 10 to 3)

⚠ **Attention:** For the connection (230 V) fixed or flexible lines with the factory-standard lead end sleeves are to be installed.

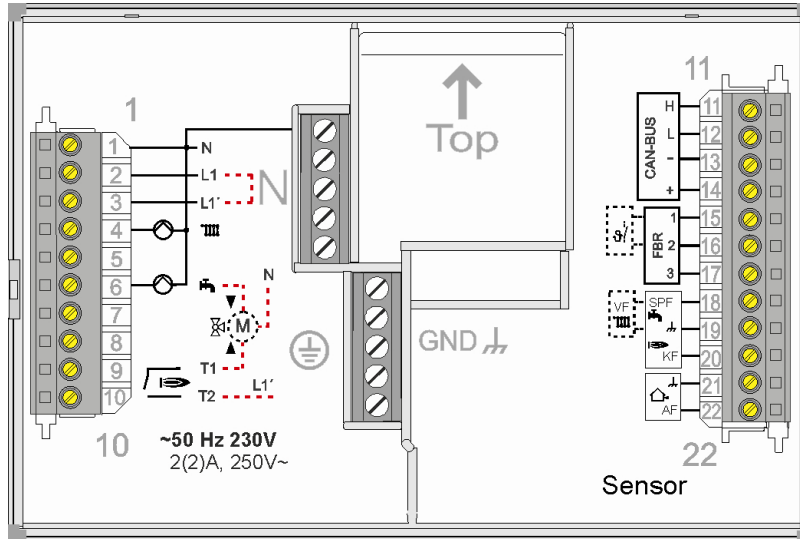

- 11 - 14 CAN BUS
- 15 - 17 FBR2
alternatively:
15 + 16 Lago switch
or room thermostat
- 18 + 19 Storage tank
sensor or HW thermo-
stat
alternatively in the case
of mixer flow sensor
- 19 + 20 Boiler sensor
- 21 + 22 Outdoor sensor
in the case of mixer for
zone control

⚠ **Attention:** Bus lines and sensor lines are to be installed separately from supply lines!

! in the event of operation without room thermostat or with timer switch, short-circuit contacts 15 and 16 using a wire jumper.

Options

Provided no separate regulations for protecting the relay apply, a bridge to supply the relay must be connected between terminals 2 and 3.

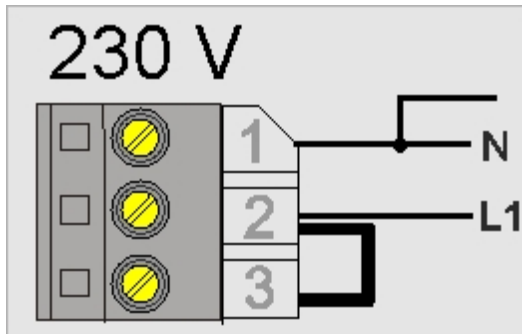
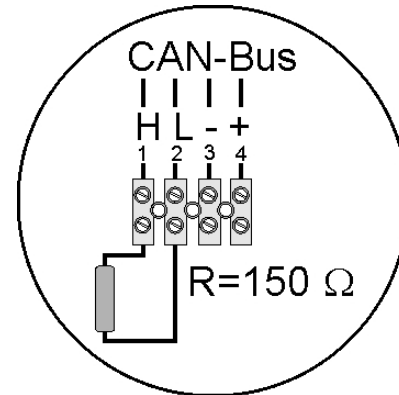
**BUS terminating resistor****Attention:**

In case of installation in systems with Stand-alone Mixer control with room device (Lago FB, BM8, etc.)

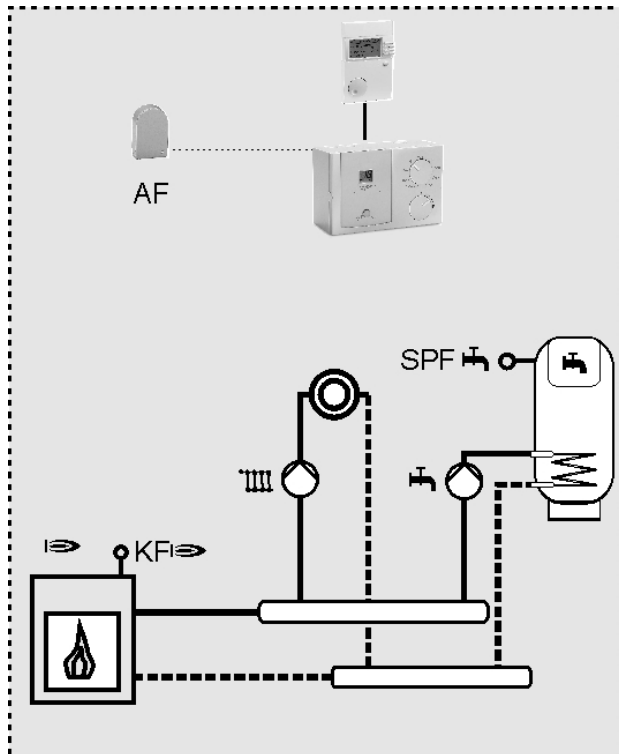
System diagrams**Boiler controller with direct heating circuit and Hot water**

BUS ID: „-„ => Boiler sensor required

°C : Setting of the flow temperature

! Note settings on the rear side of the controller

Heating circuit operation when:

- RUN and thermostat contact closed (bridge)
- Telephone switch closed (bridge)
- In the case of operating device: Enabled only via BUS

In the case of HW preparation with hot water sensor or thermostat

°C / : Set hot water set temperature

Hot water enabled when:

- RUN = 24 h
- Telephone switch contact closed (bridge)
- In the case of operating device: Only enabled via BUS

In the case of weather guidance => Outside sensor required

°C Set room set temperature and

Heat slope

In the case of room control with room sensor or FBR

°C Set room set temperature and

Room sensor influence

In the case of weather guidance or/and room control

°C : Setting of the maximum flow temperature

In the case of operation with operating module

°C , °C , , , °C / :

Settings only on operating module => At controller, display only

Boiler controller with Header pump / mixer motor expansion

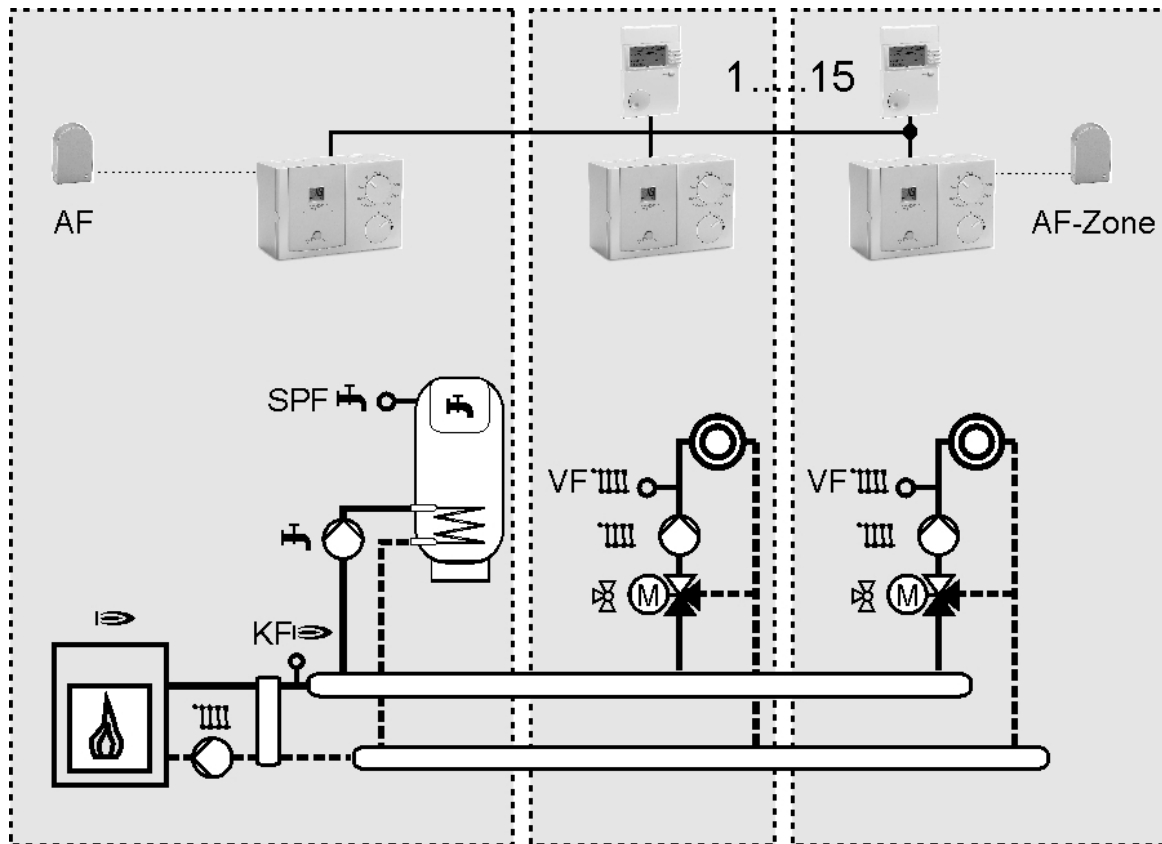



0101 Boiler controller with collector pump



BUS ID: „00,, => Boiler sensor required



! Note settings on rear side of controller.

No heating circuit!



°C  = „--,,

°C  = „--,,

  = „--,,

  = „--,,



In the case of HW preparation:

°C  / : Set hot water set temperature

Hot water enabled when:

- RUN = 24 h
- Telephone contact switch closed (bridge)
- In the case of operating device: Enabled only via BUS

In the case of operation with operating module

°C  / :

Settings only on operating module => At controller, display only

1001 Mixer extension:

No boiler sensor! => BUS ID: „01 - 15,,

! Note settings on rear side of controller.

Mixer circuit operation when:

- RUN and thermostat contact closed (bridge)
- Telephone switch contact closed (bridge)
- In the case of operating module: Only enabled via BUS

°C  / : Set mixer dynamics



In the case of weather guidance => Outside temperature required

°C  Set room set temperature and













  Heat slope

In the case of room control or FBR

°C  Set room set temperature and

  Room sensor influence

In the case of operation with operating module

°C , °C ,  ,  : Settings only on operating module °C , °C ,  ,  : At controller, display only

0101 Boiler controller in cascade operation



BUS ID: „01 - 08,, => Boiler sensor required (p 22.)



! Note settings on rear side of controller.

No heating circuit and no hot water operation!

°C  = „--,,

°C  => „--,,

  = „--,,

  = „--,,

°C  /  = „--,,

Burner operation via cascade controller with back-up protection function when the maximum temperature is reached.

Pump operation during burner operation + delayed pump switch-off.

Boiler controller in cascade operation

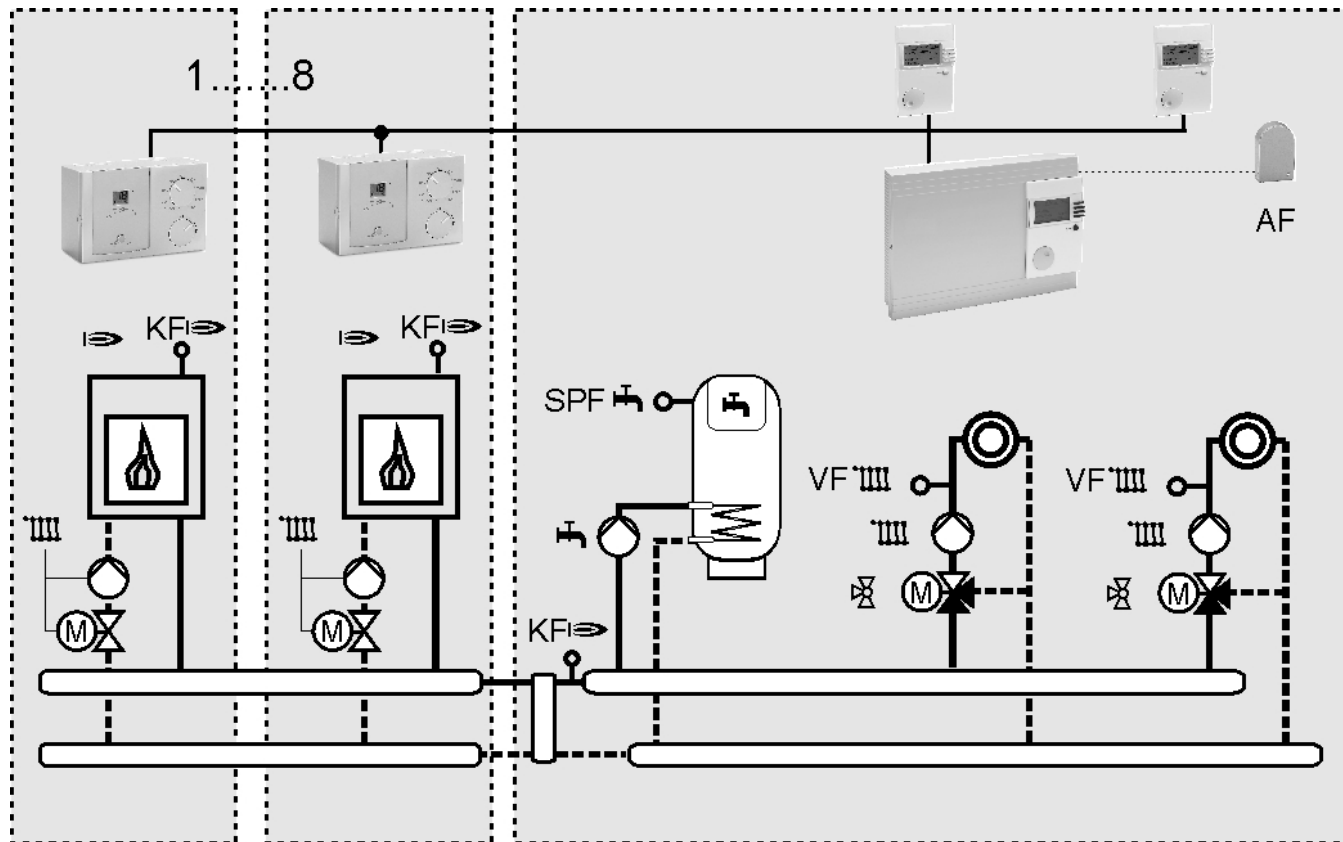

Remote controls

The operating module Merlin BM, BM 8, Lago FB

The controller permits connection of an operating module via a bus line. The operation-control module allows various operation-control functions and monitoring functions for the system values to be relocated to the main controlled zone – i.e. the living room. This achieves maximum comfort and convenience. A detailed description of the entire functional range is found in the technical descriptions of the operating modules.

- Display of the system parameters
- Entry of the heating circuit parameters
- Room temperature control
- Automatic adaption of the heat slope
(not for Lago FB)



Remote control FBR2



- Rotating switch for modifying room temperature setting
Adjusting range: (± 5 K)
 - Room control via the integrated room sensor
 - Rotating switch for selecting operating mode
 - ⏻ Standby/OFF (frost protection only)
 - ☀ Daytime operation according to thermostat input
 - 🌙 Daytime operation according to thermostat input
 - 🌙 24 h reduced mode (room regulated to 15 °C)
 - ☀ 24-hour daytime operation (comfort temperature)
 - ☀ Summer mode (heating OFF, hot water only)
- !** The heating program switch at the controller must be set to "Run".

Installation location:

- In reference / main living room of the heating circuit (on an inside wall of the room).
- Not in the vicinity of radiators or other heat dissipating units.
- Any, if the room sensor influence is switched off.

Installation:

- Remove cap from underside of pedestal.
- Secure the base at the installation location.
- Connect the electrical connection cables.
- Press the cap back on.

Sensor resistances FBR

Temperature	FBR2 terminals 1 - 2 Room sensor
+10 °C	9.950 Ω
+15 °C	7.855 Ω
+20 °C	6.245 Ω
+25 °C	5.000 Ω
+30 °C	4.028 Ω

PC

All system-specific parameters can be set and interrogated using the *ComfortSoft* parameterisation software. The parameters can be saved, displayed graphically and evaluated on the PC at predefined intervals. To connect to a PC, you need the CoCo PC active, which also supports the sending of error messages by SMS and the remote interrogation of controller data.

Maximum delimiter

If a maximum delimiter is required it must be connected between the heating circuit pump and the pump controller switch output.

Telephone switch

The heating system can be switched to Heating mode * with a telephone switch. The connection terminals of the controller for the remote control FBR (see connection diagram) are used for installation. As soon as a short circuit is detected at terminals 2 and 3 of the corresponding connector, the assigned heating circuit switches to heating operation. When the short circuit is eliminated, the controller once again heats on the basis of the set operating mode.

- △ If the heating circuit is controlled remotely by an operating module, the telephone switch must be connected at the operating module.

Sensors

Outside sensor AF (AFS)

Order no. AF, 5 k Ω : 99 679 030
Order no. AFS, 1 k Ω : 99 679 001

Scope of supply

Outside sensor, screw and dowel

Installation location:

- Wherever possible, on a northerly or north-easterly wall behind a heated room
- Approx. 2.5 m above ground
- Not above windows or ventilation shafts

Installation:

- Pull cover off sensor.
- Fasten sensor with enclosed screw
- Connect electrically



Immersion sensor KF (KFS) / SPF (SPFS)

Order no. KF/SPF, 5 k Ω , 3 m, \varnothing 6.0x50: 99 676 769
Order no. KFS/SPFS, 1 k Ω , 3 m, \varnothing 6.0x50: 99 676 682

Installation location:

- In the immersed pipe of the hot-water cylinder tank (generally on the front face of the tank)

Installation:

- Slide the sensor as far as possible into the immersed pipe.
- !** The immersed sleeve must be dry.
- Connect electrically



Strap-on sensor VF (VFAS)

Order no. VF, 5 k Ω , 3 m, \varnothing 6.0x50: 99 679 073
Order no. VFAS, 1 k Ω , 3 m, \varnothing 6.0x50: 99 679 051

Scope of supply

Flow sensor, thermal compound, retaining strap, pressure cap

Installation location:

- In the case of boiler control instead of the boiler sensor KF as close as possible behind the boiler on the heating flow pipe
- In the case of mixer operation  approx. 0.5 m behind the circulation pump

Installation:

- Thoroughly clean the flow pipe.
- Apply heat conductive paste (A)!!
- Secure sensor with stretch band.
- Connect electrically

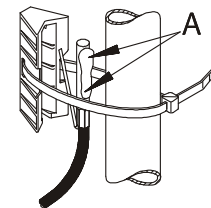

00880-01

! Only sensor of one type may be used

Sensor values / characteristic curve

Temperature	5 kOhm NTC	1 kOhm PTC
-60 °C	698961 Ω	470 Ω
-50 °C	333908 Ω	520 Ω
-40 °C	167835 Ω	573 Ω
-30 °C	88340 Ω	630 Ω
-20 °C	48487 Ω	690 Ω
-10 °C	27648 Ω	755 Ω
0 °C	16325 Ω	823 Ω
10 °C	9952 Ω	895 Ω
20 °C	6247 Ω	971 Ω
25 °C	5000 Ω	1010 Ω
30 °C	4028 Ω	1050 Ω
40 °C	2662 Ω	1134 Ω
50 °C	1801 Ω	1221 Ω
60 °C	1244 Ω	1312 Ω
70 °C	876 Ω	1406 Ω
80 °C	628 Ω	1505 Ω
90 °C	458 Ω	1607 Ω
100 °C	339 Ω	1713 Ω
110 °C	255 Ω	1823 Ω
120 °C	194 Ω	1936 Ω

Errors

When there is an error, the corresponding error number flashes.

Error no.	Error description
Communication error	
E 91	Bus ID used. The set bus ID is already in use by another device.
Internal error	
E 81	EEPROM error. The invalid value has been replaced with the default value △ Check parameter values!
Sensor defective (break/short circuit)	
E 70	Flow sensor
E 75	Outdoor sensor
E 76	Storage tank sensor
E 77	Boiler sensor
E 80	Room sensor

Resetting error number 81:
Switch mains voltage Off and On again.

Technical data

Supply voltage complying with EN 60038	AC 230 V ± 10 %
Power consumption	Max. 5 W
Switching capacity of the relays	AC 250 V 2(2) A
Maximum current on terminal L1'	6.3 A
Type of protection complying with EN 60529	IP40
Protection class complying with EN 60730-1	I
Permitted ambient temperature during operation	0 to 50 °C
Permitted ambient temperature for storage	-20 to 60 °C
Permissible humidity non condensing	%95 r.H.
Sensor resistances	NTC 5 kΩ (AF,KF,SPF,VF)
Tolerance of the resistor	+/- 1 % at 25 °C
Temperature tolerance	+/- 0.2 K at 25 °C
Tolerance of the resistor	PTC 1010 Ω (AFS,KFS,SPFS,VFAS)
Temperature tolerance	+/- 1 % at 25 °C +/- 1.3 K at 25 °C

Glossary

Flow and return flow temperature

The flow temperature is the temperature to which the heat source heats the water that transfers the heat to the consumer (e.g. radiator). The return flow temperature is the temperature of the water that flow back from the consumer to the heat source.

Desired and actual temperature

The desired temperature (or setpoint temperature) describes the desired temperature for a room or for hot water.

The actual temperature denotes the actual temperature that prevails. The heating controller has the task to adjust the actual temperature to the desired temperature.

Setback temperature

The setback temperature is the desired temperature to which the heating system heats outside heating times (e.g. at night). It should be set so that the rooms do not cool down too much while saving energy.

Heat source

Heat source is generally the designation for the heating boiler. It may also be a buffer storage tank however.

Mixed heating circuit / Mixer circuit

In the mixed heating circuit a three-way valve is used to add cooled water from the return flow to the hot flow water. The flow temperature is thus reduced. This is important for Underfloor heating systems, for example, because they must only be operated with low flow temperatures.

Heating time

In the heating programs you can define up to three heating times per day, one for the morning, one for lunchtime, and one for the evening for example. During a heating time, the temperature is controlled to the desired room temperature. Between heating times the temperature is controlled to the setback temperature.

Header pump

A header pump is used to pump the hot water in a system with one or several heat sources. It is switched on as soon as a consumer in the system requests heat.

Legionella

Legionella are bacteria that live in water. The hot water storage tank is heated to 65 °C every 20th heating period or at least once a week as protection against these bacteria.

Malfunctions due to improper operation or settings are not covered by the warranty.

If you have any technical questions, please contact your local branch office/agent.

The addresses are available on the Internet or from Elster GmbH.

We reserve the right to make technical modifications in the interests of progress.

Elster GmbH
Geschäftssegment
Comfort Controls
Kuhlmannstraße 10
31785 Hameln
www.kromschroeder.de